



Threaded One Piece Split (Clamp Type) Metric

Clamp style collars with threaded bores are also available. Threaded collars provide axial holding power superior to smooth bore collars, while offering easier installation and adjustment than solid ring locking devices.

Part No.	Thread	Pitch (mm)	O.D. (mm)	C (mm)	W (mm)	F	SS
MTCL-4-0.7	M4	0.7	16.0	20.8	9.0	✓	✓
MTCL-5-0.8	M5	0.8	16.0	20.8	9.0	✓	✓
MTCL-6-1	M6	1.0	16.0	20.8	9.0	✓	✓
MTCL-8-1.25	M8	1.3	18.0	22.4	9.0	✓	✓
MTCL-10-1.5	M10	1.5	24.0	26.3	9.0	✓	✓
MTCL-12-1.75	M12	1.8	28.0	32.0	11.0	✓	✓
MTCL-16-2	M16	2.0	34.0	39.3	13.0	✓	✓
MTCL-20-2.5	M20	2.5	40.0	47.4	15.0	✓	✓
MTCL-24-3	M24	3.0	45.0	52.1	15.0	✓	✓
MTCL-30-3.5	M30	3.5	54.0	59.2	15.0	✓	✓

✓ Stocked Size

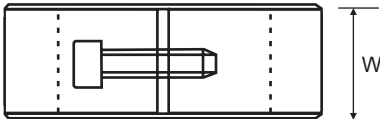
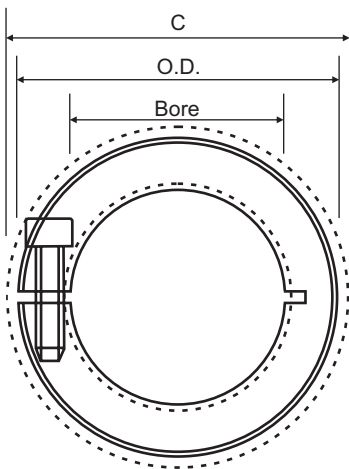

- Does not mar the shaft.
- Single point faced.
- Acme and Left-hand threads available.
- Additional sizes available.

-Width tolerance:

All

- + .08 mm
- .25 mm

Steel - Black Oxide (F)

Cold drawn bar. Hot process black oxide, impregnated with naphthenic oil, centrifugal dried.

Stainless Steel (SS)

Stainless Steel Grade 303 austenitic, non-magnetic bar with a bright finish.

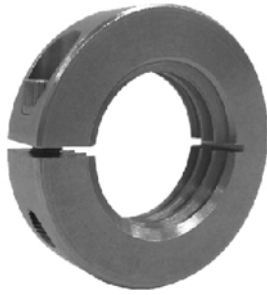

Threaded One Piece Split (Clamp Type) Inch

Clamp style collars with threaded bores are also available. Threaded collars provide axial holding power superior to smooth bore collars, while offering easier installation and adjustment than solid ring locking devices.

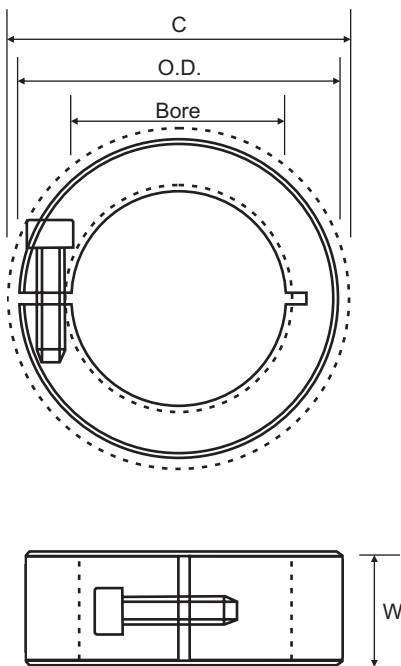

- Does not mar the shaft.
- Single point faced.
- Acme and Left-hand threads available.
- Additional sizes available.

-Width tolerance:

All

+ .003"

- .010"

Part No.	Bore (in)	T.P.I.	O.D. (in)	C (in)	W (in)	F	SS
TCL-2-32	#8 UNC	32	0.6250	0.773	0.281	✓	✓
TCL-3-24	#10 UNC	24	0.6250	0.773	0.281	✓	✓
TCL-3-32	#10 UNF	32	0.6250	0.773	0.281	✓	✓
TCL-4-20	0.2500 UNC	20	0.6250	0.773	0.281	✓	✓
TCL-4-28	0.2500 UNF	28	0.6250	0.773	0.281	✓	✓
TCL-5-18	0.3125 UNC	18	0.6875	0.838	0.281	✓	✓
TCL-5-24	0.3125 UNF	24	0.6875	0.838	0.281	✓	✓
TCL-6-16	0.3750 UNC	16	0.8750	1.027	0.343	✓	✓
TCL-6-24	0.3750 UNF	24	0.8750	1.027	0.343	✓	✓
TCL-7-14	0.4375 UNC	14	0.9375	1.080	0.343	✓	✓
TCL-7-20	0.4375 UNF	20	0.9375	1.080	0.343	✓	✓
TCL-8-13	0.5000 UNC	13	1.1250	1.281	0.406	✓	✓
TCL-8-20	0.5000 UNF	20	1.1250	1.281	0.406	✓	✓
TCL-10-11	0.6250 UNC	11	1.3125	1.500	0.437	✓	✓
TCL-10-18	0.6250 UNF	18	1.3125	1.500	0.437	✓	✓
TCL-12-10	0.7500 UNC	10	1.5000	1.808	0.500	✓	✓
TCL-12-16	0.7500 UNF	16	1.5000	1.808	0.500	✓	✓
TCL-14-9	0.8750 UNC	09	1.6250	1.916	0.500	✓	✓
TCL-14-14	0.8750 UNF	14	1.6250	1.916	0.500	✓	✓
TCL-16-8	1.0000 UNC	08	1.7500	2.032	0.500	✓	✓
TCL-16-12	1.0000 UNF	12	1.7500	2.032	0.500	✓	✓
TCL-16-14	1.0000 UNS	14	1.7500	2.032	0.500	✓	✓
TCL-18-7	1.1250 UNC	07	1.8750	2.140	0.500	✓	✓
TCL-18-12	1.1250 UNF	12	1.8750	2.140	0.500	✓	✓
TCL-20-7	1.2500 UNC	07	2.0625	2.295	0.500	✓	✓
TCL-20-12	1.2500 UNF	12	2.0625	2.295	0.500	✓	✓
TCL-22-6	1.3750 UNC	06	2.2500	2.465	0.563	✓	✓
TCL-22-12	1.3750 UNF	12	2.2500	2.465	0.563	✓	✓
TCL-24-6	1.5000 UNC	06	2.3750	2.578	0.563	✓	✓
TCL-24-12	1.5000 UNF	12	2.3750	2.578	0.563	✓	✓
TCL-28-16	1.7500 UNS	16	2.7500	3.046	0.688	✓	✓
TCL-32-12	2.0000 UN	12	3.0000	3.273	0.688	✓	✓
TCL-36-12	2.2500 UN	12	3.2500	3.504	0.750	✓	✓

✓

Stock Size

Steel - Black Oxide (F)

Cold drawn bar. Hot process black oxide, impregnated with naphthenic oil, centrifugal dried.

Stainless Steel (SS)

Stainless Steel Grade 303 austenitic, non-magnetic bar with a bright finish.