

CAL7 (Self-Centering)

Consists of one inside and one outside cone ring, which are joined by a set of screws. It is suitable for medium to high torques and is self-centering. Applications which require a very precise axial positioning are not recommended, owing to a small axial displacement of the hub during the assembly operation. Available for shaft diameters from 18 to 200 mm.

Characteristics
 Medium-high torque
 Economical
 Quick installation

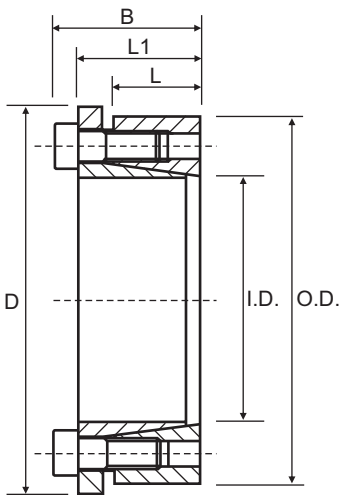

Part No.	I.D.	O.D.	L	L1	B	D	Torque Nm	Axial Force N
CAL7-18/47*	18	47	17	28	34	54	250	28000
CAL7-20/47	20	47	17	28	34	56	284	28000
CAL7-22/47	22	47	17	28	34	56	313	28000
CAL7-24/50	24	50	17	28	34	59	341	28000
CAL7-25/50	25	50	17	28	34	59	426	34000
CAL7-28/55	28	55	17	28	34	64	478	34000
CAL7-30/55	30	55	17	28	34	64	512	34000
CAL7-32/60	32	60	17	28	34	69	728	45000
CAL7-35/60	35	60	17	28	34	69	796	45000
CAL7-38/65	38	65	17	28	34	74	864	45000
CAL7-40/65	40	65	17	28	34	74	910	45000
CAL7-42/75	42	75	20	33	42	84	1544	74000
CAL7-45/75	45	75	20	33	42	84	1655	74000
CAL7-48/80	48	80	20	33	42	89	1765	74000
CAL7-50/80	50	80	20	33	42	89	1838	74000
CAL7-55/85	55	85	20	33	42	94	2311	84000
CAL7-60/90	60	90	20	33	42	99	2521	84000
CAL7-65/95	65	95	20	33	42	104	3093	95000
CAL7-70/110	70	110	24	40	50	119	4670	133000
CAL7-75/115	75	115	24	40	50	124	5004	133000
CAL7-80/120	80	120	24	40	50	129	5338	133000
CAL7-85/125	85	125	24	40	50	134	6380	150000
CAL7-90/130	90	130	24	40	50	139	6755	150000
CAL7-95/135	95	135	24	40	50	144	7923	167000
CAL7-100/145	100	145	26	44	56	154	9714	194000
CAL7-110/155	110	155	26	44	56	164	10686	194000
CAL7-120/165	120	165	26	44	56	174	13114	219000
CAL7-130/180	130	180	34	54	66	189	18943	291000
CAL7-140/190	140	190	34	54	68	199	20993	300000
CAL7-150/200	150	200	34	54	68	209	24992	333000
CAL7-160/210	160	210	34	54	68	219	29324	367000
CAL7-170/225	170	225	44	64	78	234	33989	400000
CAL7-180/235	180	235	44	64	78	244	35989	400000
CAL7-190/250	190	250	44	64	78	259	47485	500000
CAL7-200/260	200	260	44	64	78	269	49984	500000

Torque = Maximum transmittable torque when axial force is zero.
Axial Force = Maximum axial force when transmittable torque is zero.

For CAL7 use the following tolerances

h8 for the shaft
 H8 for the hub

* Discontinued size, Limited stock available
 All dimensions in mm unless otherwise stated

Locking Bush Conversion Chart

SIT (CAL)	TOLLOK (TLK)	Lovejoy (SLD)	MAV	RINGFEDER (RFN)	RINGBLOK	BIKON	COMPOMAC (Conex)	KTR (Clampex)
CAL1	200	1500	2005	7012	1120	4000	A	100
CAL2	300	350	3003	8006	1060	5000	C	150
CAL3	110	1900	5061	7110.1	1100	8000	B	250
CAL4	450	2600	4061	7005	1800	1012	F	400
CAL5A	130		6901	7004	1300.1	7000A	D	200
CAL5B	131		6902	7007	1300.2	7000B	E	201
CAL6	132	1850 1350	1062	7013.0 7003	1710	1003	DS	203
CAL7	133	1750 1450	1061	7013.1 7006	1720	1006	ES	206
CAL8	134		3061		2400	1506	EP	225
CAL9	250		3505		1500C	5500SP	H	125
CAL10	500		1004	7020	1600	9500	M	700
CAL11S	603	900	2008	4071	2200.01	1029.71	SD	603
CAL12S	139		4005	9009	1000	4500	L	90
CAL13S	250L		3705		1500	5500S	I	125.1
CAL15	350			7061				105

External diameters and torque ratings may vary between suppliers

