

CAL8 (Self-Centering)

Consists of one inside and one outside cone ring, which are joined by a set of screws. It is suitable for medium torques and is self-centering. Applications which require a very precise axial positioning are recommended. Available for shaft diameters from 14 to 50 mm.

Characteristics

Medium-low torque
Economical
Quick installation

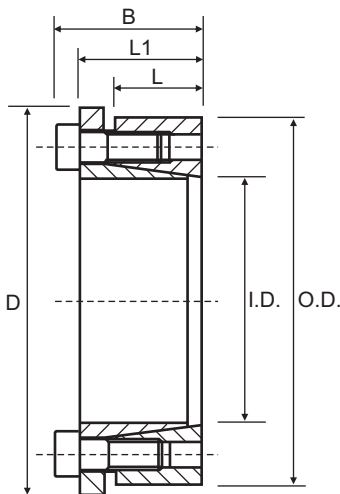

Part No.	I.D.	O.D.	L	L1	B	D	Torque Nm	Axial Force N
Diam -55 (O.D.)								
CAL8--14/55	14	55	17	30	38	62	130	19000
CAL8--16/55	16	55	17	30	38	62	149	19000
CAL8--18/55	18	55	17	30	38	62	168	19000
CAL8--19/55	19	55	17	30	38	62	177	19000
CAL8--20/55	20	55	17	30	38	62	186	19000
CAL8--22/55	22	55	17	30	38	62	288	26000
CAL8--24/55	24	55	17	30	38	62	314	26000
CAL8--25/55	25	55	17	30	38	62	328	26000
CAL8--28/55	28	55	17	30	38	62	441	32000
CAL8--30/55	30	55	17	30	38	62	473	32000
Diam -65 (O.D.)								
CAL8--24/65	24	65	17	31	39	72	448	37000
CAL8--25/65	25	65	17	31	39	72	467	37000
CAL8--28/65	28	65	17	31	39	72	611	44000
CAL8--30/65	30	65	17	31	39	72	655	44000
CAL8--32/65	32	65	17	31	39	72	699	44000
CAL8--35/65	35	65	17	31	39	72	919	53000
CAL8--38/65	38	65	17	31	39	72	998	53000
CAL8--40/65	40	65	17	31	39	72	1051	53000
Diam -80 (O.D.)								
CAL8--30/80	30	80	20	34	42	87	785	52000
CAL8--32/80	32	80	20	34	42	87	837	52000
CAL8--33/80	33	80	20	34	42	87	863	52000
CAL8--35/80	35	80	20	34	42	87	1070	61000
CAL8--38/80	38	80	20	34	42	87	1162	61000
CAL8--40/80	40	80	20	34	42	87	1223	61000
CAL8--42/80	42	80	20	34	42	87	1544	74000
CAL8--45/80	45	80	20	34	42	87	1655	74000
CAL8--48/80	48	80	20	34	42	87	1765	74000
CAL8--50/80	50	80	20	34	42	87	1838	74000

Torque = Maximum transmittable torque when axial force is zero.

Axial Force = Maximum axial force when transmittable torque is zero.

For CAL8 use the following tolerances

h8 for the shaft

H8 for the hub

All dimensions in mm unless otherwise stated

Locking Bush Conversion Chart

SIT (CAL)	TOLLOK (TLK)	Lovejoy (SLD)	MAV	RINGFEDER (RFN)	RINGBLOK	BIKON	COMPOMAC (Conex)	KTR (Clampex)
CAL1	200	1500	2005	7012	1120	4000	A	100
CAL2	300	350	3003	8006	1060	5000	C	150
CAL3	110	1900	5061	7110.1	1100	8000	B	250
CAL4	450	2600	4061	7005	1800	1012	F	400
CAL5A	130		6901	7004	1300.1	7000A	D	200
CAL5B	131		6902	7007	1300.2	7000B	E	201
CAL6	132	1850 1350	1062	7013.0 7003	1710	1003	DS	203
CAL7	133	1750 1450	1061	7013.1 7006	1720	1006	ES	206
CAL8	134		3061		2400	1506	EP	225
CAL9	250		3505		1500C	5500SP	H	125
CAL10	500		1004	7020	1600	9500	M	700
CAL11S	603	900	2008	4071	2200.01	1029.71	SD	603
CAL12S	139		4005	9009	1000	4500	L	90
CAL13S	250L		3705		1500	5500S	I	125.1
CAL15	350			7061				105

External diameters and torque ratings may vary between suppliers

